

Fits: Standard Bent Bolt, Large-Ring, German K-98's, Czech VZ-24, Yugo 48/48a, Turkish 1903/1937, 1938, 1946 etc. 7mm or 8mm caliber

Thank you for purchasing one of Advanced Technology Inc.'s Stocks!
Please fill out the enclosed Unconditional Lifetime Warranty card and mail it within 30 days of purchase.



MAUSER 98 STOCK LARGE RING 8MM/7MM ETC...

The Mauser 98 Stock will fit all LARGE-RING, "Standard" BENT-BOLT Mausers including German K-98, Czech VZ-24, Yugo 24/47, Yugo 48/48A, Turkish 1903/1937/1938/1946, etc...*Note: Straight-bolt and "Wide-arc" bolts must use our Conversion Bolt Handle Part# MBH-1800. This quality stock includes a built-in scope mount and is made of black, glass filled nylon. *It is designed to be used with a rifle scope ONLY!* Virtually indestructible, waterproof and includes an Unconditional Lifetime Warranty. Follow these instructions carefully for assembly. Will **NOT** fit large ring Swedish Mauser M38/M96 6.5x55 or SMALL ring Mausers, (Spanish M1916 .308)etc...

INSPECT MAGAZINE AND CHAMBER TO BE SURE THEY ARE EMPTY.

Important: Note the location of the Serial Number on YOUR Mauser.

Use a file or dremel tool to remove stock material so that the serial number will be visible after the stock is installed.

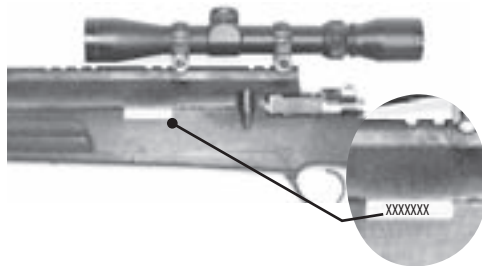

STEP #1

Determine if the Advanced Technology, Inc. Bolt Handle Conversion is necessary. Install now, if needed. (See **MAUSER BOLT HANDLE**)

STEP #2

Remove the barreled action from the existing stock. Then remove handguard from the barreled action.

STEP #3

REMOVE REAR SIGHT

Example (A): Driveout retaining pin, then push the front of the sight downward and pull rearward to remove sight.

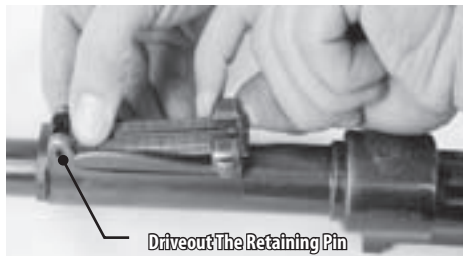

Example (B): Driveout retaining pin, then use small punch and tap the spring toward the front sight. Then lift out rear sight.

Note: These are only two examples for rear sight removal.

STEP #4

Place clamps (included) on barrel between receiver and the rear sight bracket as shown, with the top (4) threaded holes "UP", and the side (4) threaded holes to the left of the receiver. Install and tighten the (2) # 10-32 x 1/2" Socket Head Cap Screws (SHCS) in the counterbored holes at the top and place the (2) #10-32 x 3/4" Socket Head Cap Screws (SHCS) in the lower side holes but do not tighten. Place the scope rail over the clamp. Install and tighten the (4) #8-32 x 1/2" Socket Head Cap Screws.

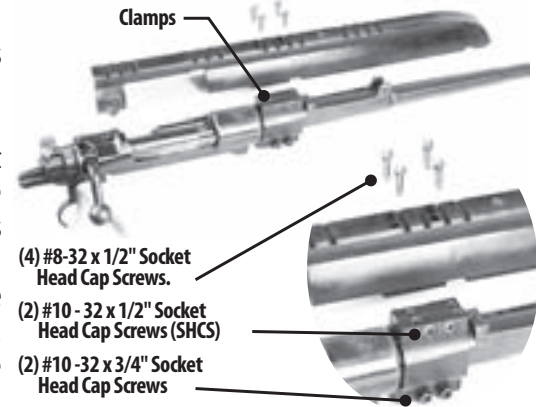

STEP #5

Place the barreled action with the scope rail and clamp into the stock. Align the scope rail as necessary by rotating slightly or moving back and forth. Once properly aligned, remove barreled action and scope rail from the stock and tighten the bottom (2) 10-32 x 3/4" Socket Head Cap Screws. This "locks" the Scope Mount Clamp on the barrel.

STEP #6

The recoil lug spacer allows this stock to fit various Mausers. Place the action into the stock. Reinstall and tighten both original barreled action mounting screws. Observe oblong hole in stock and check for gap. If the gap in the oblong hole is to the rear, then the recoil spacer must be installed. The goal is to ensure full contact between the recoil lug and the stock. Remove the action from the stock. Insert recoil spacer, if required, into the matching holes in the stock.

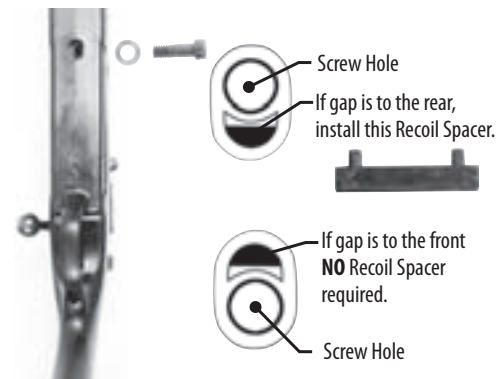

STEP #7

Remove the spring and follower from the old trigger guard/magazine by grasping the bottom of the spring and pulling rearward, free of its retaining grooves. Place the spring inside the magazine well, with the shell-follower face-up.



Fits: Standard Bent Bolt, Large-Ring, German K-98's, Czech VZ-24, Yugo 48/48a, Turkish 1903/1937, 1938, 1946 etc. 7mm or 8mm caliber

STEP #8

Install rear action mounting screw.

Place supplied 1/4" washer over front action mounting screw and install. Tighten both screws.



A. Place the barreled action with the scope rail back into the stock.

B. Place the (2) #6 x 1" screws into the rear holes on the scope rail and partially tighten into the stock.

C. Lay rifle on its side, place the (2) #8 x 2" screws into the front underside holes in the stock. Visually align the tip of each screw into the holes on the scope mount. Tighten all 4 screws. **CAUTION: Do NOT Overtighten these #6 x 1" or #8 x 2" Screws.**

CONGRATULATIONS! STOCK INSTALLATION IS NOW COMPLETE.

OPTIONAL CHEEK REST

STEP #9

Locate the most comfortable position on stock to position the cheek rest. Use tape to hold it in the correct position. Using a 9/64" bit, drill both holes. Secure the cheek rest with the 2 supplied #8 x 1 1/4" screws. **Do NOT Overtighten.**



MAUSER BOLT HANDLE



Straight-Bolt and "Wide-Arc" Bolt Mausers must use our Mauser Bolt Handle (part# MBH1800) to convert to bent-bolt in order to mount a scope!

#MBH 1800
\$19.99
MSRP



Straight Bolt
Must Convert



Standard Bent Bolt
No Conversion

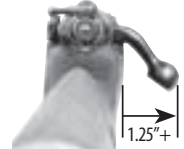

"Wide Arc" Bolt
Must Convert

OTHER PRODUCTS AND ACCESSORIES FROM ADVANCED TECHNOLOGY, INC.

TRANSFORM YOUR RIFLE

with Products from Advanced Technology, Inc.

Create a weatherproof, durable hunting rifle with stocks & accessories that are easy to install at affordable prices. Manufacturer's Unconditional Lifetime Warranty. Virtually indestructible stocks. Made of Matte Black, Glass-Filled Nylon.



SKS Fiberforce Stock
#SKS 3000 **\$69.99**
MSRP



AK Fiberforce Stock
#MAK 0100 **\$69.99**
MSRP



SKS Fixed/Folding Ultralight Stock
#SKS 0200 **\$59.99**
MSRP



SKS Monte Carlo Stock
#SKS 0300 **\$59.99**
MSRP



Mosin Nagant Monte Carlo Stock
#MOI 0300
\$69.99
MSRP



Enfield Monte Carlo Stock No4, Mk1
#ENF 0041 Shown
\$69.99
MSRP

Also available
Enfield Monte Carlo
Stock No1, Mk3
#ENF 0013



Marlin or Ruger Fiberforce Stock
#MAR 3000
#RUG 3000
\$59.99
MSRP



Mauser 98 Stock with Built-in Scope Mount
#MSS 1500
\$79.99
MSRP

