

MOS0100: Fits: Mossberg 500/590 & Maverick 88 12GA

REM0100: Fits: 12GA Remington 870

Thank you for purchasing one of Advanced Technology Inc.'s SHOTFORCE COMPONENTS!
Please fill out the enclosed Unconditional Lifetime Warranty card and mail it within 30 days of purchase.



Fits 12GA Mossberg 500/590/835, Maverick 88
(Forend does not fit Maverick), or Remington 870.

ASSEMBLY INSTRUCTIONS - BUTTSTOCK

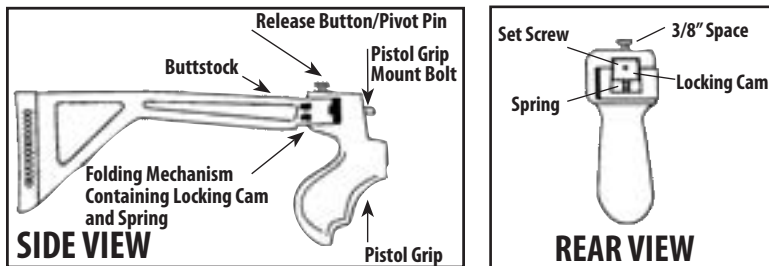

MAKE SURE YOUR SHOTGUN IS UNLOADED BEFORE STARTING!

- STEP 1** Remove the butt plate or recoil pad from the rear of the stock by unscrewing the two mounting screws.
- STEP 2** Insert a long flat-blade screwdriver into the hole in the rear of the stock & remove the long stock screw.
- STEP 3** Remove the stock from the shotgun.
- STEP 4** Put the side-folding stock in the folded position. Use an allen wrench to loosen the set screw in the stock locking cam. Turn twice to loosen.
- STEP 5** Pull upward on the release button/pivot pin & remove.
- STEP 6** Hold pistol grip in left hand and with right hand push buttstock to rear as far as possible. It will snap back approximately a half inch.
- STEP 7** Slide both the locking cam and spring to rear and remove from mechanism.
- STEP 8** Remove buttstock from the pistol grip, being careful to keep pistol grip mount bolt.
- STEP 9** Install pistol grip on shotgun using allen wrench.
- STEP 10** Place buttstock back in pistol grip in folded position and slide rearward (reverse of disassembly). Install cam and spring with screw facing to the rear.
- STEP 11** Slide buttstock, cam and spring forward and align pivot hole.
- STEP 12** Replace the release button/pivot pin into pivot hole.
- STEP 13** Leave space 3/8 inch between the pin head and top of the pistol grip.
- STEP 14** Tighten set screw.
- STEP 15** Unfold and fold stock, checking for any necessary final adjustments.

TO INSTALL FOREND

MAKE SURE YOUR SHOTGUN IS UNLOADED BEFORE STARTING!

REMINGTON 870 INSTALL

- STEP 1** Engage safety switch.
- STEP 2** Pull forend all the way rearward and then forward approximately half way.
- STEP 3** Unscrew magazine cap and remove barrel.
- STEP 4** Depress and hold the left shell stop (see figure #2).
- STEP 5** Slide forend forward off magazine tube. Note: the bolt and slide block will also be removed (see figure #3).
- STEP 6** With forend removed, unscrew forend ring nut from the front of tube and remove old forend by pulling it forward off the tube.
- STEP 7** Install new forend.
- STEP 8** Place ring nut on forend tube and tighten.
- STEP 9** To reassemble, slide forend back on magazine tube and replace bolt and slide block (see figure #3). Place action bars into receiver and pull rearward until it stops.
- STEP 10** Press right shell stop (see figure #4). The forend with the bolt will slide further rearward and stop again. Now press left shell stop (see figure #2) and the forend will travel fully to the rear.
- STEP 11** Slide the forend forward approximately halfway and replace barrel and magazine cap.

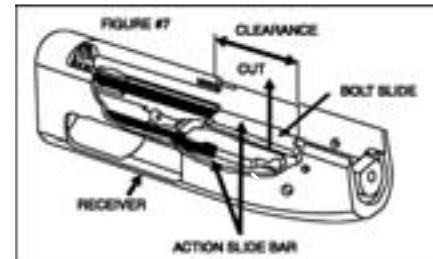
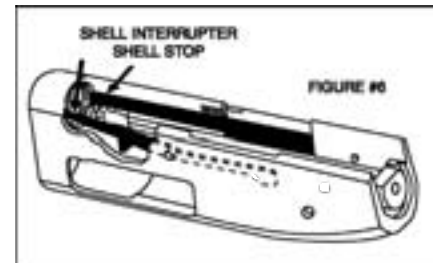
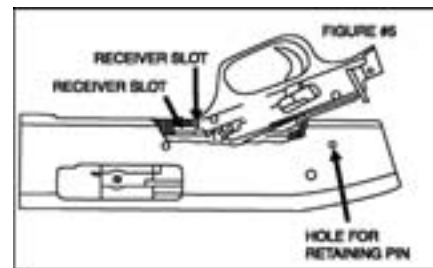
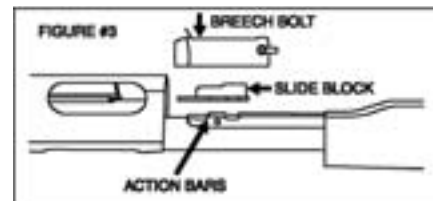
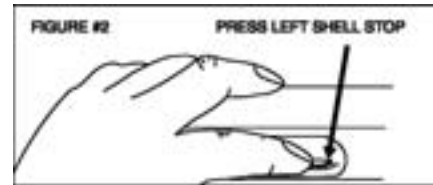

MOS0100: Fits: Mossberg 500/590 & Maverick 88 12GA

REM0100: Fits: 12GA Remington 870

TO INSTALL FOREND

MAKE SURE YOUR SHOTGUN IS UNLOADED BEFORE STARTING!

MOSSBERG INSTALL

NOTE: MOSSBERG FOREND MODIFICATION FOR THE NEW MOSSBERG 500 PUMP "SHORT FOREND TUBE"

Mossberg has assembled shotguns with two different lengths of Forend Tubes. The long Forend Tube will pass through the New Forend without altering the New Forend. However, the short Forend Tube will require that the New Forend be altered because it will not extend through the New Forend. The following steps will instruct you how to alter the New Forend to fit the shorter Forend Tube.

Use saw (hacksaw or if Dremel tool is used, use LOW RPM setting to prevent melting the Glass Filled Nylon) to extend the recessed sides from the rear to the second valley toward the front (see figures #8, #9), new length is approximately 2.0 inches from rear of Forend (see figure #10). Use file to square off the cut surface and to remove stock from the inside surface adjacent to the recess length just cut.

On the inside of the forend, there are three ribs located 3/4 from the rear of the forend (see figure #8). These ribs must be shortened to obtain a new length of 1 3/4 (see figure #9) from the rear of the forend to allow the forend tube to slide forward into the forend. A dremel tool with grinding attachment can be used to remove the three ribs. A file can be used to smooth up the surface. CAUTION: DO NOT REMOVE EXCESS MATERIAL.

The ears on the forend tube must contact the cut surface on the forend at the 2 inch length (see figure #10).

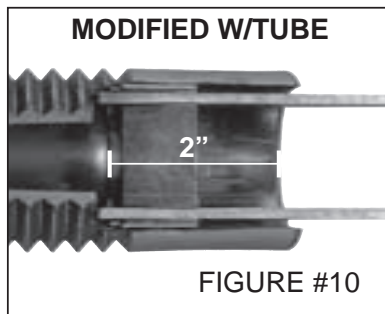
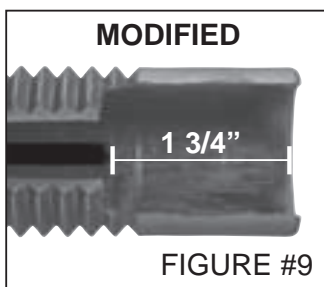
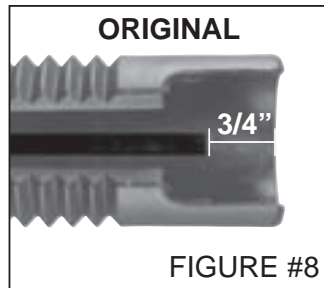

- STEP 1** Cycle action once to make sure hammer is cocked and engage safety.
- STEP 2** Depress slide release and pull forend approximately halfway rearward, loosen magazine cap and remove barrel.
- STEP 3** Remove trigger group retaining pin by tapping it out with a blunt pin no greater than 3/16 inch in diameter.
- STEP 4** Place shotgun upside down and pull out trigger group by lifting up at the rear (see figure #5).
- STEP 5** Remove shell interrupter and shell stop from receiver (see figure #6).
- STEP 6** Align bolt slide with cut out in receiver by moving forend and action bars back and forth.
- STEP 7** Remove bolt slide upward (see figure #7).
- STEP 8** Pull forend and action bars forward and remove from magazine tube.
- STEP 9** With forend removed, unscrew forend ring nut from the front of tube and remove old forend by pulling it forward off the tube.
- STEP 10** Install new forend.
- STEP 11** Place ring nut on forend tube and tighten.
- STEP 12** Place forend back on magazine tube and align action bars with the openings in the receiver.
- STEP 13** Align the slots on the action bars with the slots on the bolt slide and replace bolt slide (see figure #7).
- STEP 14** Replace both the shell interrupter and shell stop (see figure #6).
- STEP 15** Replace trigger group and pin (see figure #5).
- STEP 16** Depress slide release and slowly pull Forend full length to verify that New Forend does not interfere with front of receiver. If interference occurs, use file to increase width at rear of Forend to clear receiver or cut off end of forend.

More components available for Moss/Rem Win 12/20GA Pump Shotguns:

